

Clamping lever kits

adjustable, for clamp mountings

SPECIFICATION

Handle
Zinc die casting
plastic coated
silver, RAL 9006, textured finish

Insert / Distance bushing
Stainless Steel AISI 303

INFORMATION

For clamp mountings, the clamping kits GN 511 replace the hexagon socket screw DIN 912. It is used on all clamping points where repeated clamping actions are required, e.g. for adjusting a stop mechanism. The matching clamping kits for each clamping thread are listed in the dimensional tables of the clamp mountings.

TECHNICAL INFORMATION

- Stainless Steel characteristics (see page A26)

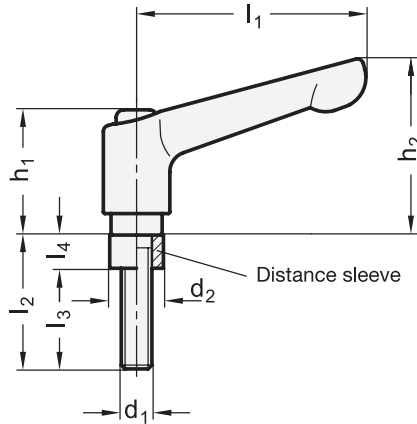

GN 511

Description	d1	l2	d2	l1	l3	l4	h1	h2	⚖
GN 511-M4-14	M 4	14	7,5	22	9,5	4,5	18,5	23	39
GN 511-M4-16	M 4	16	7,5	22	11,5	4,5	18,5	23	39
GN 511-M4-20	M 4	20	7,5	22	15,5	4,5	18,5	23	41
GN 511-M5-16	M 5	16	9	30	10	6	24,5	30,5	41
GN 511-M5-20	M 5	20	9	30	14	6	24,5	30,5	41
GN 511-M5-25	M 5	25	9	30	19	6	24,5	30,5	41
GN 511-M6-20	M 6	20	10,5	45	13,5	6,5	24,5	35	41
GN 511-M6-25	M 6	25	10,5	45	18,5	6,5	24,5	35	51
GN 511-M6-30	M 6	30	10,5	45	23,5	6,5	24,5	35	52
GN 511-M6-32	M 6	32	10,5	45	25,5	6,5	24,5	35	52

